

QUICK OPERATING 1/4-TURN FASTENERS

5F SERIES

5F Series. Miniature Stud Assemblies and Receptacles

Features: Minimum stud head projection.

- Wide range of head styles. • Variety of materials.
- Stud available with either retaining ring or snap-in grommet for quick assembly

Small and compact, these fasteners feature a high strength-to-weight ratio. They are specifically designed for use on miniaturized equipment.

Note: Part numbers shown are basic part numbers only. See ordering information on Page A-18 and A-19 for required dash numbers.

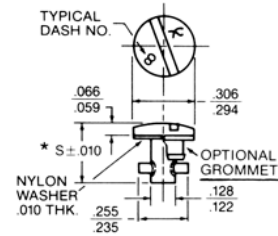

* $S = .264 + (.015 \times \text{Dash No.})$
Slotted Recess

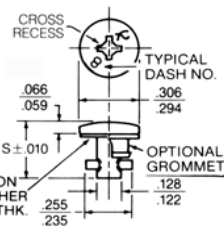

* $S = .264 + (.015 \times \text{Dash No.})$
Cross Recess

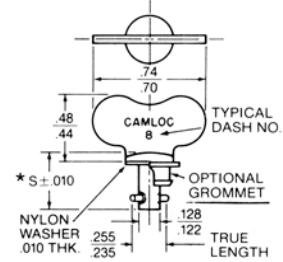

* $S = .264 + (.015 \times \text{Dash No.})$
Fixed Wing

Material	Used With Retaining Ring		With Nylon Snap-in Grommet**		Used With Retaining Ring	With Nylon Snap-in Grommet**	
	Used With Retaining Ring	With Nylon Snap-in Grommet**	Used With Retaining Ring	With Nylon Snap-in Grommet**		Used With Retaining Ring	With Nylon Snap-in Grommet**
Stainless Steel	5S35-[]	5S34-[]-[]BB	5S15-[]	5S54-[]-[]BB	—	5S55-[]-[]BB	
Steel (Cadmium Plated)	5S5-[]	5S34-[]-[]AA	5S1-[]	5S54-[]-[]AA	5S10-[]	5S55-[]-[]AA	
Steel (Nickel Plated)	5S27-[]	—	—	—	5S28-[]	—	
Steel (Satin Black Enamel)	5S5-[]A	—	—	—	—	—	
Steel (Chrome Plated)	—	—	—	—	—	—	
Maximum Service Temperatures	300°F.		5S15 = 550°F. (Supplied with S.S. washer in lieu of nylon.) All others 300°F.		300°F.		

Plastic Knob Styles

Basic Part Nos.

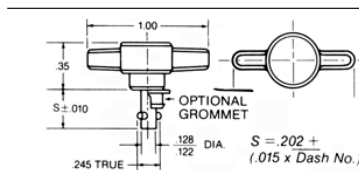

T-Knob
Used With
Retaining Ring

With Nylon
Snap-in Grommet**

Shank Material: Steel (zinc plated) Maximum Service Temperature: 300°F.

	Black	Red	Grey	Beige
5S58-[]-1AA	5S58-[]-1AB	5S58-[]-1AC	5S58-[]-1AD	
5S51-[]-[]AA	5S51-[]-[]AB	5S51-[]-[]AC	5S51-[]-[]AD	
5S59-[]-1AA	5S59-[]-1AB	5S59-[]-1AC	—	
5S52-[]-[]AA	5S52-[]-[]AB	5S52-[]-[]AC	—	

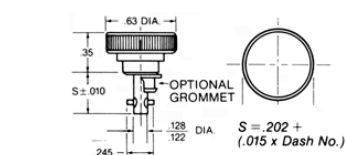

Knurled Knob
Used With
Retaining Ring

With Nylon
Snap-in Grommet**

** **Note:** Use of grommet increases maximum head protrusion .030 inch.

QUICK OPERATING 1/4-TURN FASTENERS

5F SERIES

A

Typical Assembly

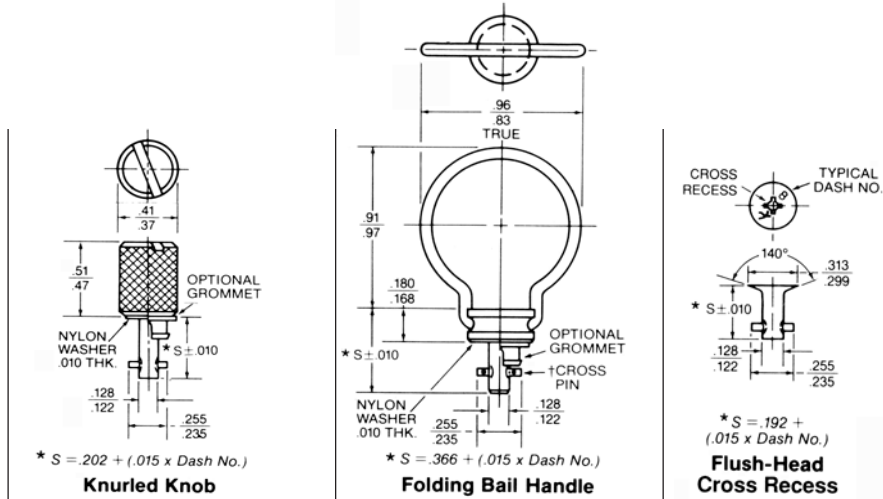
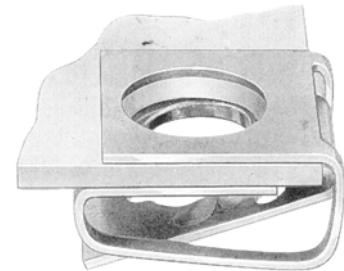
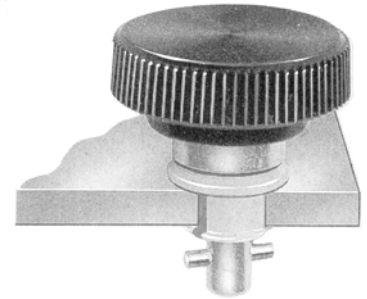

	Used With Retaining Ring	With Nylon Snap-in Grommet**	Used With Retaining Ring	With Nylon Snap-in Grommet**	Used With Retaining Ring
	5S25-[]B	5S57-[]-]BB	5S37-[]-2BB	5S60-[]-[]BB	5S44-[]-1AA
	—	—	5S37-[]-1AA	5S60-[]-[]AA	5S7-[]
	—	—	—	—	—
	—	—	—	—	—
	5S25-[]	5S57-[]-[]AA	—	—	—
	300°F.		5S37-[]-2BB version: 550°F. (supplied with stainless steel washer in lieu of nylon). Steel versions: 300°F.		5S7=450°F. 5S44=550°F.

† The position of handle relative to cross pin varies by part number.

Specifications:

Ultimate tensile strength: 150 lbs.
 Working strength: 100 lbs.
 Stud grip increments: .015 inch
 For optional styles, materials and finishes, contact the Camloc Products Division.

Retaining Ring

Order separately. Retaining Ring not required when Snap-in Grommet style is specified.

See Page A-58 for installation.

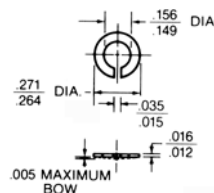

Part No.	Material	Maximum Service Temperature
5S3-1	Steel (Cadmium Plated)	450°F.
5S3-2	Stainless Steel	550°F

Weight per 100 pcs.: .02 lbs.

QUICK OPERATING 1/4-TURN FASTENERS

5F SERIES

Receptacles

Clip-on Type

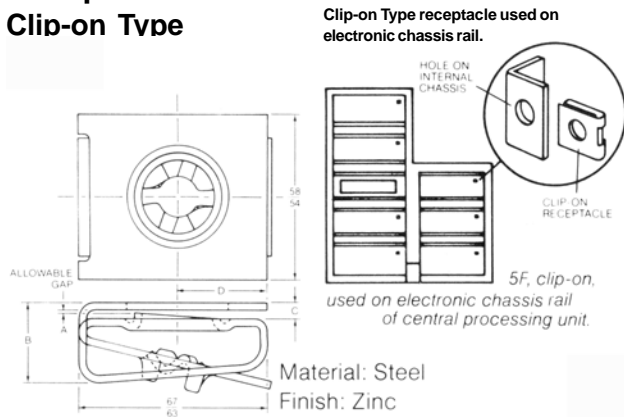

Part No.	A Ref.	B	C	D
5R16-1-1AA	.010	.29 .25	.08 .04	.33 .29
5R16-2-1AA	.085	.37 .33	.15 .11	.26 .22

Standard or Side Mounting Versions

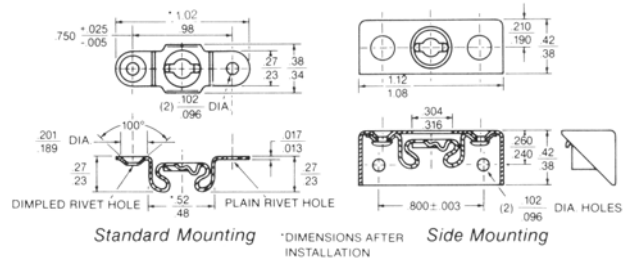

Standard Mounting Part No.	Side Mounted Part No.	Material	Rivet Holes	Temp.
5R2-1	5R3-1	Steel (Cad. Plated)	Plain	450°F.
5R2-2	—	Steel (Cad. Plated)	Dimpled	450°F.
5R2-3	—	Stainless Steel	Plain	550°F.
5R2-4	—	Stainless Steel	Dimpled	550°F.

(5R2) weight per 100 pcs.: 0.21 lbs.
(5R3) weight per 100 pcs.: 0.54 lbs.

Panel Preparation and Installation Data

Studs with Snap-In Grommet

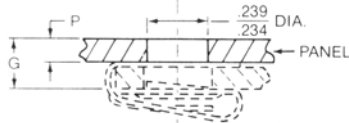

Form through hole to .234-.239 diameter. Panels with thicknesses greater than .115 inch must be back counterbored to a concentric .375 inch diameter with a remaining material thickness of .115 inch max. Note: Snap-in grommets will protrude from the backside of the panel. Minimum total thickness "G" must be observed to prevent grommets from jamming against the receptacle.

P max.	G min.
.070	.095
.115	.140

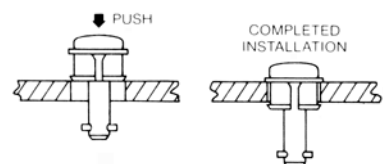

Place stud/grommet assembly on hole and push down to snap into place.

Protruding Head Studs with Retaining Ring

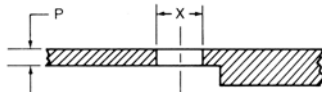

Determine panel thickness "P" and form through hole to corresponding "X" diameter. Note: Panels with thicknesses greater than .090 inch must be back counterbored to a concentric .375 inch diameter with a remaining maximum material thickness of .090 inch.

P	X dia.
up to .054	.215-.225
.055-.090	.229-.239

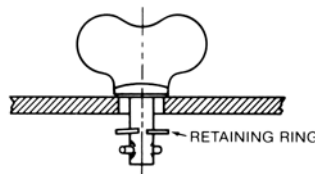

Insert stud through panel and attach retaining ring.

Flush Head Studs with Retaining Ring

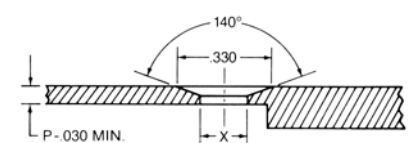

Panel preparation is the same as for protruding heads except countersink is required as shown. A minimum panel "P" thickness of .030 inch is recommended.

P	X dia.
.030-.054	.205-.215
.055-.090	.229-.239

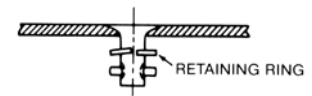

Insert stud through panel and attach retaining ring.

Panel Preparation and Installation Data (Continued)

Frame Preparation for Receptacle Installation (Rivet Type)

5R2 Standard Mount

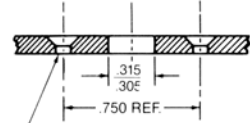

(2) HOLES C'SK FOR .093 DIA. RIVETS*

Drilled and Countersunk Rivet Holes

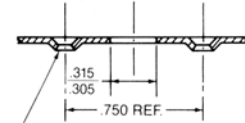

(2) HOLES DIMPLED FOR .093 DIA. RIVETS*

Dimpled Rivet Holes

5R3 Side Mount

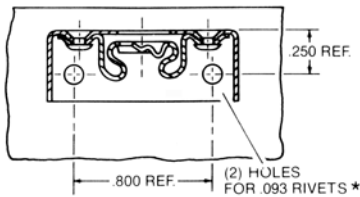

(2) HOLES FOR .093 RIVETS*

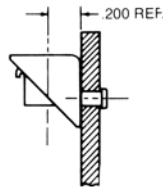

* RIVETS NOT FURNISHED

Stud Ejector Spring For Plain Rivet Holes

Provides full retraction of stud assembly to allow opening and closing of equipment without the possibility of jamming or damage.

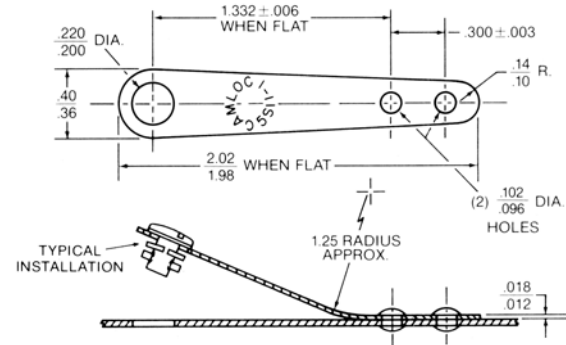

Part No.	Material and Finish	Temperature
5S11-1	Spring Steel (Cad. Plated)	450°F.
5S11-1A	Spring Steel (Black Finish)	450°F.

Note: Add .015 to total "G" thickness when using this part.
Weight per 100 pcs.: .23 lbs.

Frame Preparation for Clip-On Receptacle Installation

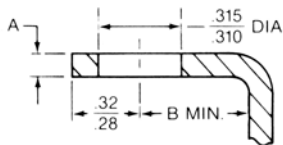
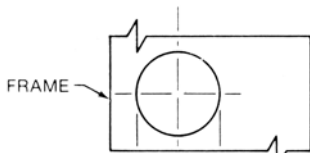

Form through hole to .310-.315 diameter .

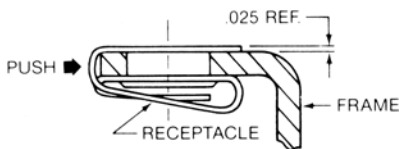

Slide receptacle onto frame and locate on through hole.

Part No.	A Frame Thickness	B Min.
5R16-1-1AA	.001-.080	.35
5R16-2-1AA	.081-.130	.35

Recessed Frame

Standard installation will cause minimum gap of .025 inch between panel and frame due to receptacle protrusion. To eliminate gap, dimple frame to provide recess as shown.

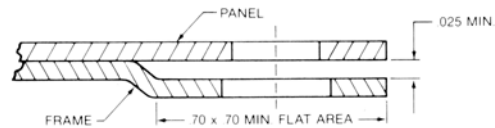

5F SERIES. Order Information/Stud and Grommet Dash Number Selection. Using Clip-On Receptacles.

To Select Stud Dash Number.

1. Determine "G" thickness.
Note: Increase "G" to allow for thickness of paint or other finishes and for the compressed thickness of any gasket.
2. Stud dash number varies with retention method (Retaining Ring vs. Snap-in Grommet). This information must be known before proceeding.
3. Locate "G" total thickness from the table below right.
4. Then find the corresponding stud dash number in the column designated for the selected method of retention.
5. When using Snap-in Grommets, specify the Grommet dash number corresponding to top panel thickness "P".

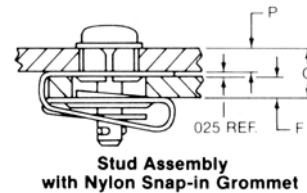

How to Order:

Example 1.

(For stud assemblies using retaining ring)

Stud Assembly Used: 5Sb- [?]
 "G" Total Thickness = .160 inch
 Retention Method = Retaining Ring
 Stud Dash Number From Table = -17
 Complete Part Number: 5S5-17

Example 2.

(For Stud assemblies using snap-in grommet)

Stud Assembly Used: 5S34-[]-[]-AA

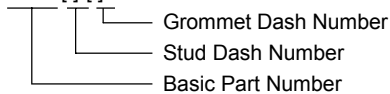

"G" Total Thickness = .160 inch
 Stud Dash Number from Table = -18
 "P" Panel Thickness = .053
 Grommet Dash Number From Table = -5
 Complete Part Number: 5S34-18-6-AA

GROMMET DASH NUMBER SELECTION		
P Max.	Dash Numbers	G Min.
.055	- 5*	.080
.070	- 6	.095
.115	- 9	.140
.145	-11*	.170

*Contact Camloc

Stud Part Number Structure

5S71-[]-1AC

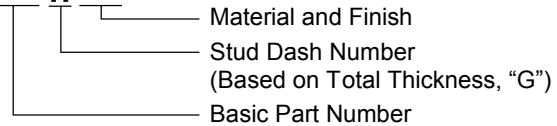

For Studs Used With Clip-On Receptacles

Stud Dash Number Selection		
G Total Thickness	Stud Assembly	
	Dash Numbers For Studs Using Retaining Rings	Dash Numbers For Studs With Snap-in Grommets
.050-.064	-10	-11
.065-.079	-11	-12
.080-.094	-12	-13
.095-.109	-13	-14
.110-.124	-14	-15
.125-.139	-15	-16
.140-.154	-16	-17
.155-.169	-17	-18
.170-.184	-18	-19
.185-.199	-19	-20
.200-.214	-20	-21
.215-.229	-21	-22
.230-.244	-22	-23
.245-.259	-23	-24
.260-.274	-24	-25

***Note:** If "G" total thickness is very near the top of the thickness range, selection of the next greater dash number is recommended. For "G" thicknesses greater than those tabulated, contact Camloc Products Division.

Using Rivet Type Receptacles.

To Select Stud Dash Number.

1. Determine "G" thickness.

Note: Increase "G" to allow for thickness of paint or other finishes and for the compressed thickness of any gasket.

2. Stud dash number varies with retention method (Retaining Ring vs. Snap-in Grommet) and with the receptacle used. This information must be known before proceeding.

3. Locate "G" total thickness from the table below.

4. Then find the corresponding stud dash number in the column designated for the selected combination of retention and receptacle.

5. When using Snap-in Grommets, specify the Grommet dash number corresponding to top panel thickness "P".



5R2 STANDARD MOUNT RECEPTACLE

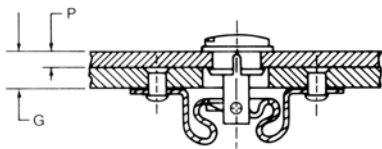

Note: Add .015 to total "G" thickness when using stud ejector spring.

5R3 SIDE MOUNT RECEPTACLE

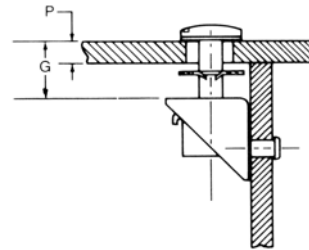

How to Order:

Example 1.

(For stud assemblies using retaining rings.)

Stud Assembly Used: 5S5-[?]

"G" Total Thickness = .160 inch

Receptacle Used = 5R2 (Standard Mount)

Retention Method = Retaining Ring

Stud Dash Number From Table = -10

Complete Part Number: 5S5 -10

Example 2.

(For stud assemblies using snap-in grommets.)

Stud Assembly Used: 5S34 - [?] - [?] - AA

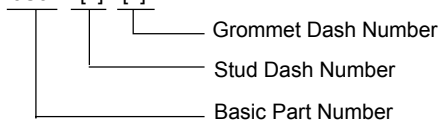

"G" Total Thickness = .160 inch

Receptacle Used = 5R2 (Standard Mount)

Retention Method = Snap-In Grommet

Stud Dash Number From Table = -11

"P" Panel Thickness = .053

Grommet Dash Number From Table = -6

Complete Part Number: 5S34-11-6

GROMMET DASH NUMBER SELECTION		
P Max.	Dash Numbers	Min. Grip
.070	-6	.095
.115	-9	.140

For Studs Used With Standard Or Side Mount Receptacles

G Total Thickness	Stud Dash Number Selection			
	Stud Assembly			
	Dash Numbers For Studs Using Retaining Rings		Dash Numbers For Studs With Snap-In Grommets	
	Receptacles		Receptacles	
	5R2 Std. Mount	5R3 Side Mount	5R2 Std. Mount	5R3 Side Mount
.020 -.034	- 1	- 2	-	-
.035 -.049	- 2	- 3	-	-
.050 -.064	- 3	- 4	-	-
.065 -.079	- 4	- 5	-	-
.080 -.094	- 5	- 6	-	-
.095 -.109	- 6	- 7	- 7	- 8
.110 -.124	- 7	- 8	- 8	- 9
.125 -.139	- 8	- 9	- 9	- 10
.140 -.154	- 9	- 10	- 10	- 11
.155 -.169	- 10	- 11	- 11	- 12
.170 -.184	- 11	- 12	- 12	- 13
.185 -.199	- 12	- 13	- 13	- 14
.200 -.214	- 13	- 14	- 14	- 15
.215 -.229	- 14	- 15	- 15	- 16
.230 -.244	- 15	- 16	- 16	- 17
.245 -.259	- 16	- 17	- 17	- 18
.260 -.274	- 17	- 18	- 18	- 19
.275 -.289	- 18	- 19	- 19	- 20
.290 -.304	- 19	- 20	- 20	- 21
.305 -.319	- 20	- 21	- 21	- 22
.320 -.334	- 21	- 22	- 22	- 23
.335 -.349	- 22	- 23	- 23	- 24
.350 -.364	- 23	- 24	- 24	- 25
.365 -.379	- 24	- 25	- 25	-
.380 -.394	- 25	-	-	-

Important Note: If the total thickness "G" is very near the top of the thickness range, selection of the next greater dash number is recommended. For "G" thickness greater than those tabulated, contact Camloc Products Division.